

Thermowells

Thermowells Questionnaire

Customer data

Company	Date
Name	Phone
Department	Fax
Address	E-mail

Process conditions

Process medium:	<input type="checkbox"/> liquid	<input type="checkbox"/> gaseous	<input type="checkbox"/> vaporous
Density of medium (kg/m ³):	Flow rate (m/s):		
Max. working temperature (°C):	Max. working pressure (bar):		

Thermowell details

Measuring point / TAG-No.	Details:	Bore size	Details:
Model / version		Insertion length	Details:
<input type="checkbox"/> solid machined	Details:	Thermowell dimension	Details:
<input type="checkbox"/> fabricated	Details:	Total length	Details:
Thermowell material	Details:		
Connection to thermometer			
<input type="checkbox"/> female thread	Details:		
<input type="checkbox"/> male thread	Details:		
Process connection			
<input type="checkbox"/> flange connection	Details:		
<input type="checkbox"/> screwed connection	Details:		
<input type="checkbox"/> weld diameter	Details:		

Example of version with flange

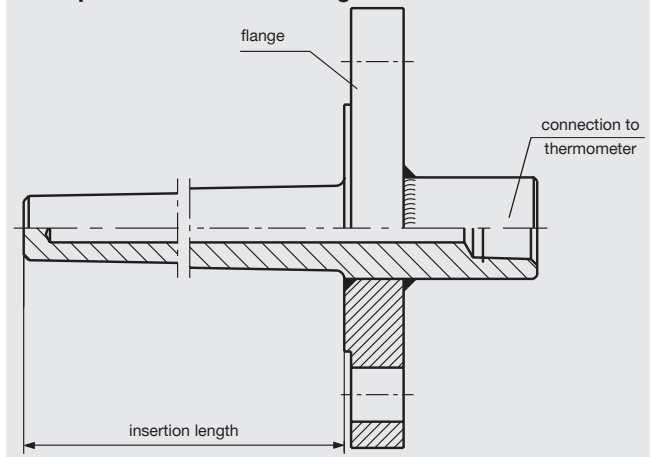

Example of screwed connection version

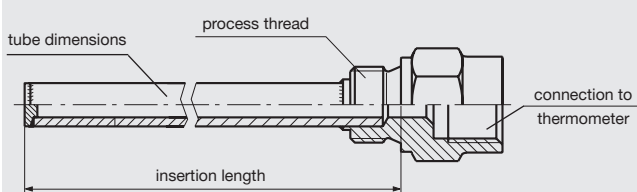

Example of weld-in type version

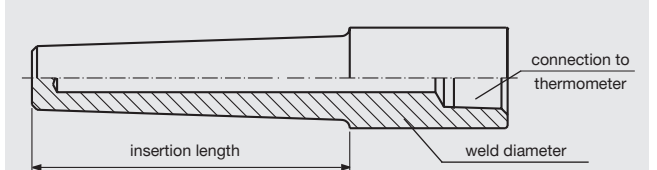

An optimal selection and calculation is only possible if the questionnaire is completed in full. Please delete where not applicable.

Space for your sketch

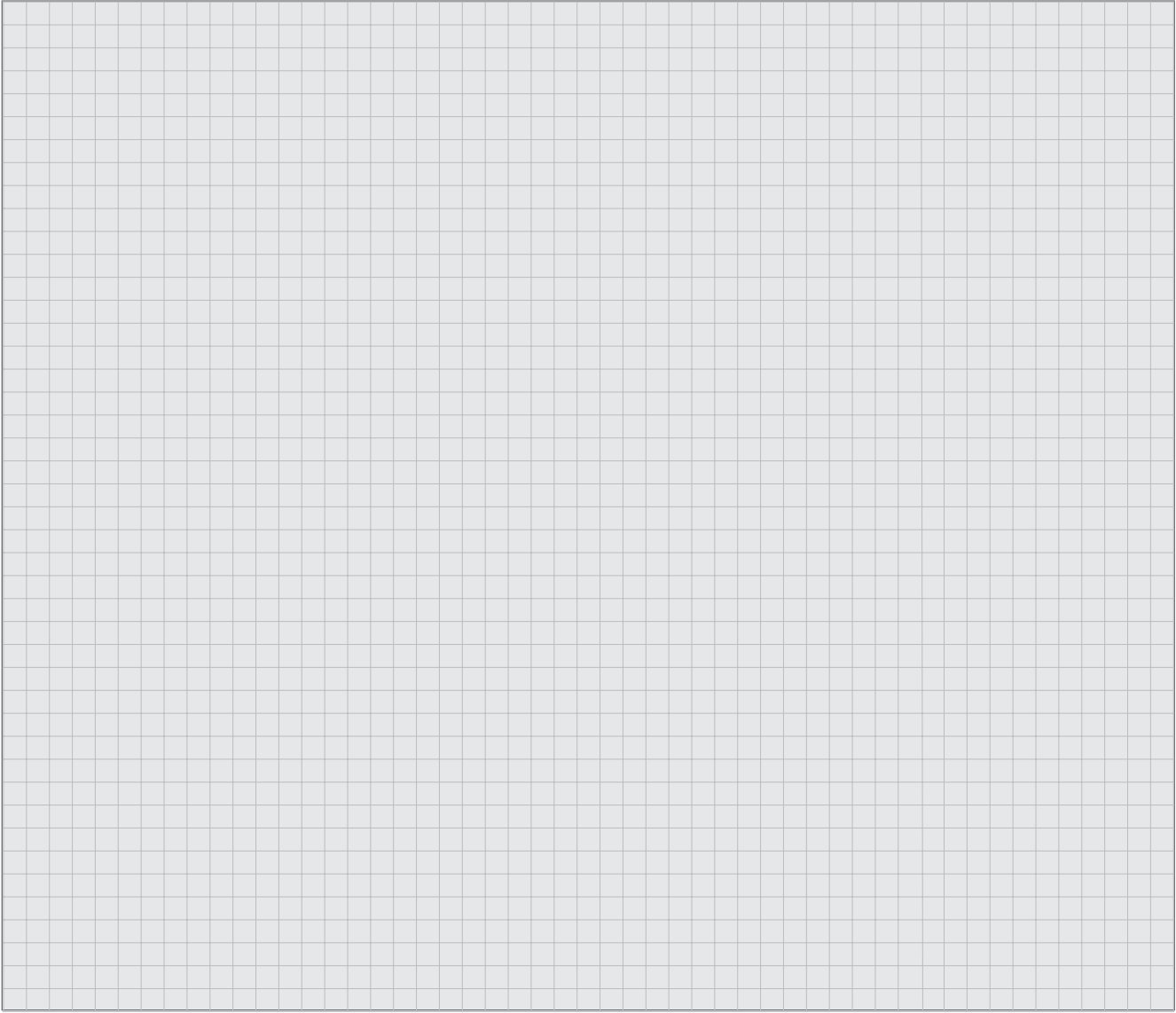

Notes
